



IMI CORNELIUS INC ■ One Cornelius Place ■ Anoka, MN 55303-6234

Telephone (800) 238-3600

Facsimile (800) 535-4321

INSTALLATION INSTRUCTIONS, BIN STAT KIT, P/N 630000408

These Bin Stat kits apply to all “I” Series Ice makers

Table 1. Loose-Shipped Parts

Item No.	Part No.	Name	Qty.
1	630900413	Spacer, Hex 5/8" Long x 8-32 SS	1
2	70894	Screw MA 08-32 TRPH 24 SS	1
3	51348	Spacer	1
4	630000413	Thermostat Asy	1
5	620037008	Bin Stat Support	1
6	630460064INS	Installation Instruction, Thermostat	1
7	168833002	Washer SR 4W SS E#8	1

1. Disconnect power.
2. Remove front cover of the unit and the electrical box cover plate.
3. Carefully insert the coiled capillary tube through the bottom hole in the electrical box where the electrical wires are coming through (see Figure 4).
4. If there is not a hole already in the chassis base, drill a 1/2" hole in the chassis base as indicated in Figure 3.
5. Straighten approximately 12" of cap tube to go through hole. Re-coil the remainder. Do not disturb coiled end.
6. Insert the "1/4" diameter wire form support into the coiled end of capillary tube and insert the assembly through the hole in the chassis base. Route capillary tube to follow support as closely as possible.
7. Remove the 8-32 nut (closest to the 1/2" DIA hole) that holds the compartment wall to the base. The adapter kits that have a single level, adapter kits P/N's 02390, 630200153, 08006, 02388, 08004, 630000191 and 08010) require a 7/8" high spacer be used to mount the binstat support. Thread the 8-32 x 5/8" hex spacer on to the compartment stud. Then fasten the thermostat support to the hex spacer using the 1/4" high plastic spacer, #8 flat washer and 8-32 x 3/4" long phil. head screw. **The spacers are not to be used on the elevated adapter kits. Refer to Figure 2.**
8. Any excess capillary tubing must be pulled back into the compressor compartment to prevent ice from damaging it during dispenser operation.
9. Seal 1/2" diameter hole with sealant (RTV).

10. To mount bin thermostat in electrical box:
 - A. Clean the mounting area by rubbing briskly with Scotch Brite pad (see Figure 4 for location).
 - B. Wipe down the cleaned area with rubbing alcohol and let dry.
 - C. Pull paper strip off of double sided tape on thermostat mounting bracket.
 - D. Being sure that bin thermostat is facing the correct direction, (see Figure 4) affix the thermostat in the electrical box. Press firmly down on the mounting bracket to bound the tape.
11. Connect the bin thermostat lead to the circuit board (see Figure 1).
12. Turn bin stat adjustment screw clockwise until it stops. Then turn it counterclockwise 1/8 of a turn.
13. Reinstall the front cover of the electrical box and the ice machine and reconnect the power. Verify that the Bin Stat is working by holding ice on the coiled bare capillary tube. The bin stat will allow the ice machine cycle to complete and harvest ice. Then the ice machine will shut down. Remove the ice from the capillary tube and warm the tube with hand heat. The ice machine should start in approximately 60 seconds.

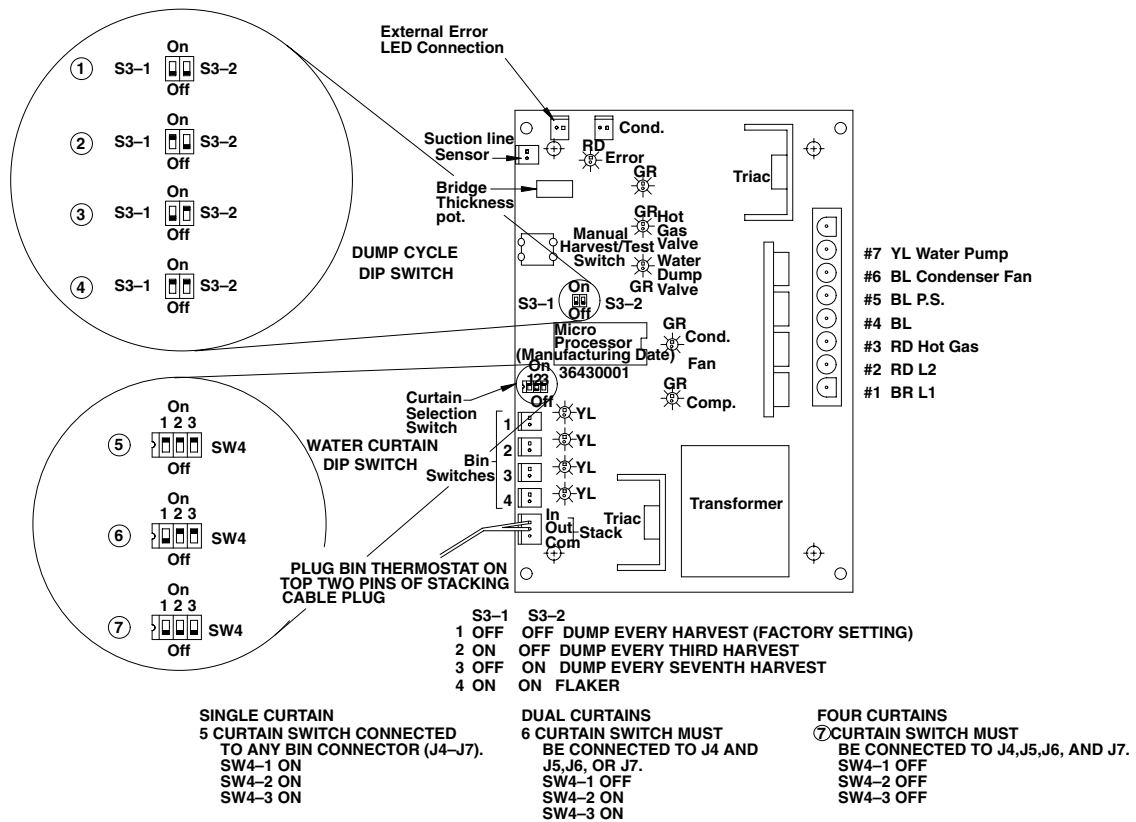

DUE TO UPGRADING OF CIRCUIT BOARD
 NOTE LOCATION OF SENSORS AND WIRE CONNECTIONS ON NEW BOARD.
 FOLLOW SETTINGS #1-#4 FOR HARVEST SETTINGS.
 FOLLOW SETTINGS #5-#7 FOR NUMBER OF CURTAINS.

Figure 1

STATUS INDICATOR

D1-2 3-4	Yellow LED	Water Curtain(s)-Dip switch can be set for 1,2, or 4 curtain units
D9	Red LED	Error
D12	Green LED	Hot Gas Valve(s)
D13	Green LED	Condenser Fan
D14	Green LED	Water Pump
D15	Green LED	Compressor Contactor
D16	Green LED	Dump Valve

Water Curtain(s) Open

D1-2 3-4	Yellow LED	(on or off)	Curtain(s) Closed Curtain(s) Open
-------------	------------	-------------	--------------------------------------

Pre-Chill Mode

D1-2 3-4	Yellow LED	(on)	Water Curtain(s) closed.
D13	Green LED	(on or off)	Condenser fan cycles on and off depending upon condenser temperature. *
D15	Green LED	(on)	Contactor closed, compressor active.

Ice Making Mode

D1-2 3-4	Yellow LED	(on)	Water Curtain(s) closed.
D13	Green LED	(on or off)	Condenser fan cycles on and off depending upon condenser temperature. *
D14	Green LED	(on)	Water pump active at evaporator temperature of 20° F or lower, except during dump cycle.
D15	Green LED	(on)	Compressor contactor closed.

Harvest Mode

D1-2 3-4	Yellow LED	(on)	Water Curtain(s) closed.
D14	Green LED	(on) 15 sec.	Water pump active for 15 sec., then deactivate.
D15	Green LED	(on)	Compressor contactor closed - Compressor active.
D16	Green LED	(on) 15 sec.	Dump valve active (15 sec.)

Error LED

D9	Red LED		Turns on when the system is shut down.
D9	Red LED	(on) or flashing	Assists to indicate where the error may be and or what may have caused the error.
D9	Red LED	(on)	Evaporator temperature drops below, 25° F.
D9	Red LED	(on)	OPEN THERMISTOR CIRCUIT - Thermistor open / broken wire / poor connector
D9	Red LED	(on) 15 sec.	High evaporator temperature: evaporator does not fall below 40° F within 6 minutes into freeze cycle.
D9	Red LED	Flashing 1/2 sec. on/ 1/2 sec. off	High temperature shutdown- condenser temperature exceeds 150° F +2, -6° F. High temperature shutdown- condenser temperature exceeds 150°

- * [Remote & water cooled use a resistor plug in J-3 connector] 1.8K ohm.
- * [Remote & water cooled use a resistor plug in J-3 connector] Fan does not
- * [Remote & water cooled use a resistor plug in J-3 connector] cycle.
- * [Remote & water cooled use a resistor plug in J-3 connector]

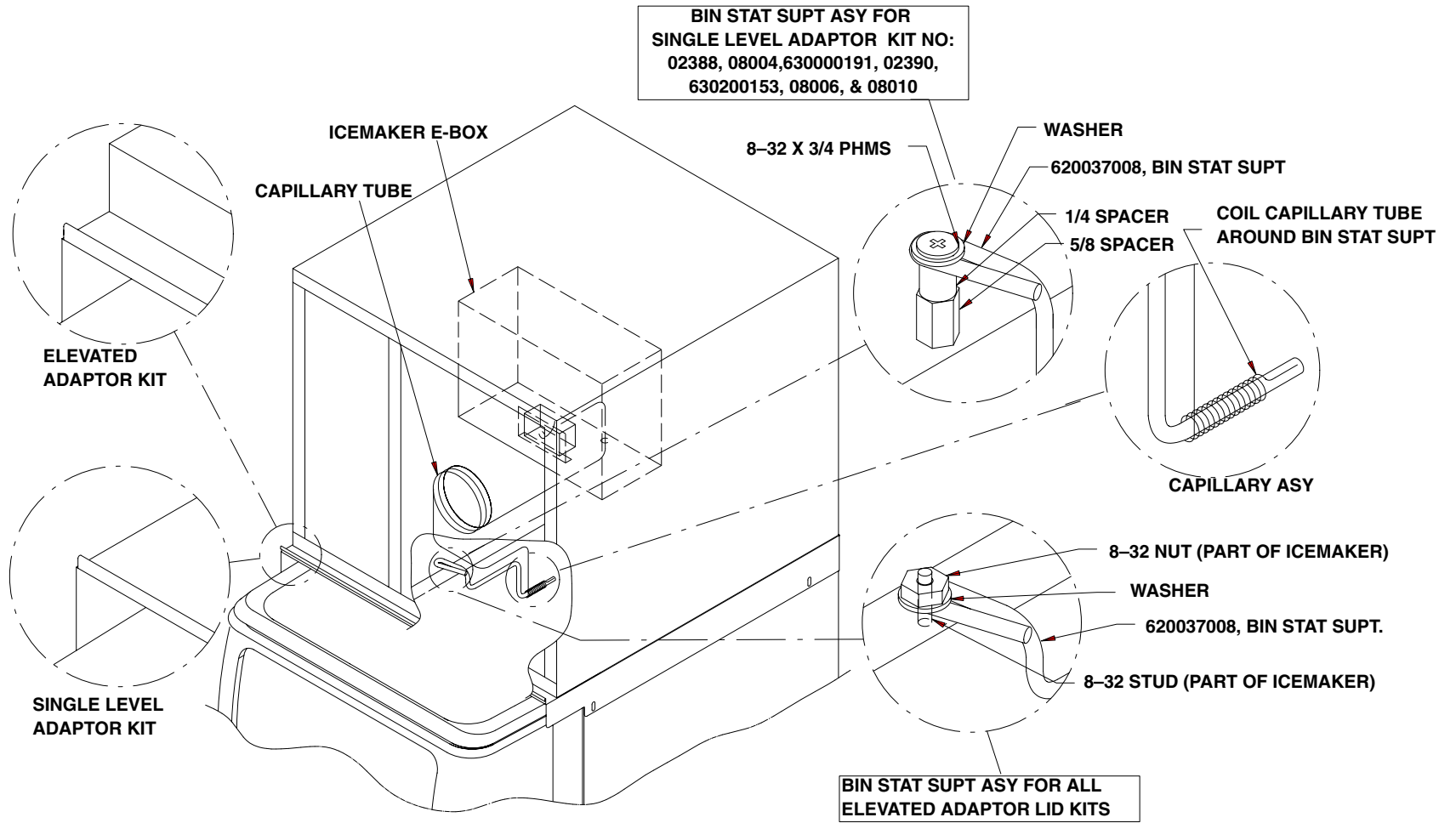

FIGURE 2

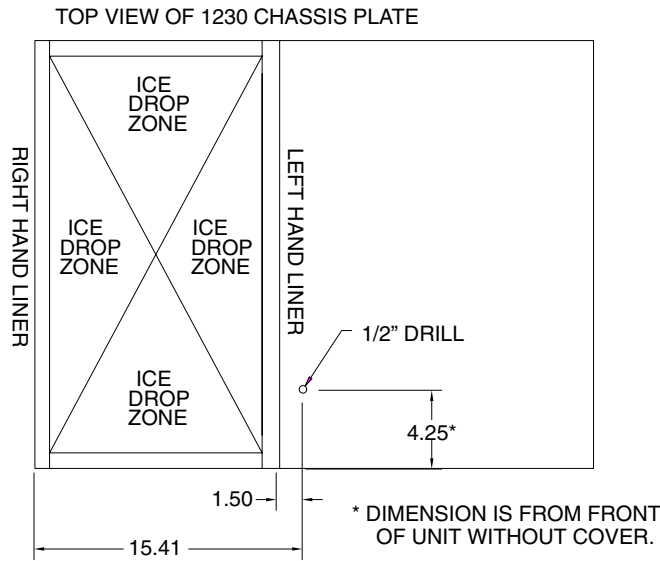

Figure 3

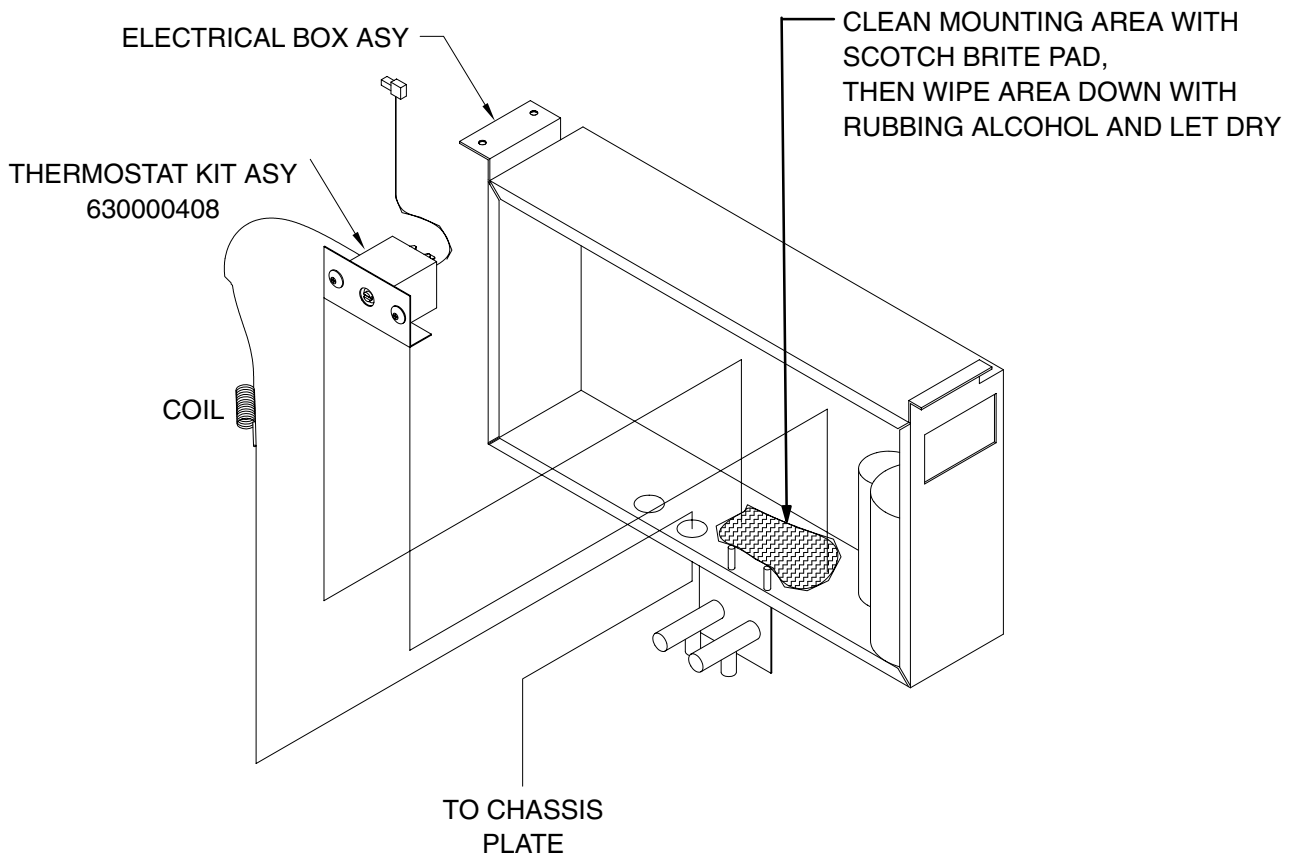

Figure 4